

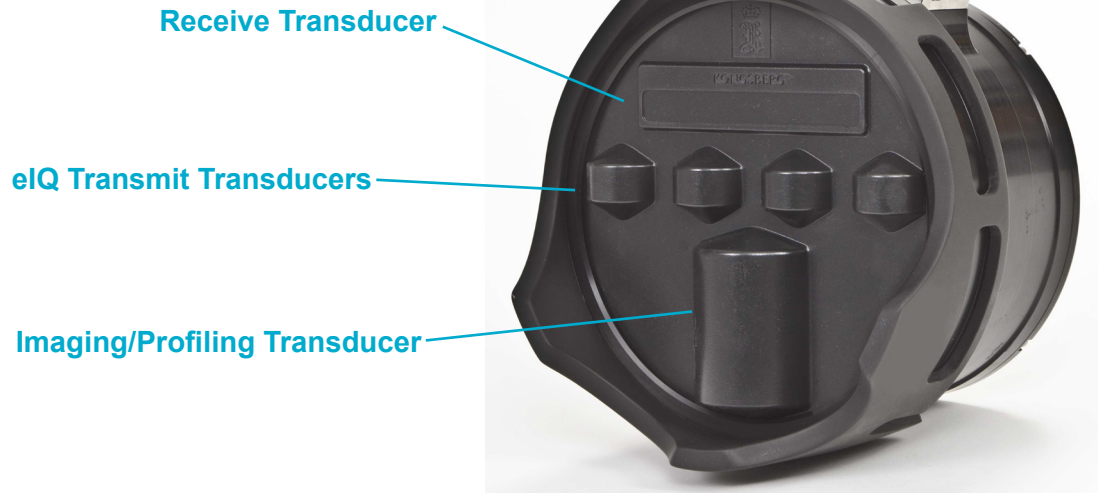

KONGSBERG

M3 SONAR - 500M

P/N 922-20010000



June 2014

THE MULTIMODE MULTIBEAM FOR MULTIPLE APPLICATIONS

- **Imaging and profiling capabilities**
- **GeoTIFF output for image mosaics**
- **Multiple true-zoom windows**
- **CHIRP and Doppler modes of operations**
- **User-friendly interface**
- **Significant time savings**
- **Integrated tilt and pan/tilt control**

The Kongsberg Mesotech M3 Sonar is a multibeam system with both imaging and profiling capabilities. The M3 Sonar provides high-resolution and easy to interpret images by combining the rapid refresh rate of a conventional multibeam sonar with image quality comparable to a single-beam sonar.

Detection of small objects out to 150 meters combined with a 120° to 140° field of view allows the operator to see the complete underwater picture in real-time.

APPLICATIONS

- Marine Engineering
- Shallow Water Bathymetric Surveying
- Site Inspection
- Environmental Monitoring
- Site Clearance
- Defense and Security

INSTALLATION OPTIONS

- Pole mount on a surface vessel
- Suitable for a wide range of vehicles from large work-class ROVs to small observation class ROVs
- Tripod mounted

M3 SOFTWARE

The M3 Software was developed specifically for the M3 Sonar to manage communications with the head and operate all beam-forming and imaging processing.

Four Pre-Defined Operating Modes:

1. **Imaging:** long range navigation with high speed update rate
2. **Enhanced Image Quality (eIQ):** greatest image quality (0.95° angular resolution) from a short range with a slower update
3. **ROV Navigation:** selects eIQ or imaging based on range
4. **Profiling:** narrow 3° beam used to generate a 3D point cloud

TECHNICAL SPECIFICATION

Sonar Specifications

Range: 0.2m to 150m
 Range Resolution: 1cm
 Frequency: 500 kHz
 Pulse Types: CW, CHIRP
 Modes: Variable Vertical Beamwidth, eIQ

Imaging Mode

Horizontal Field of View: 120°
 Vertical Beamwidth: 3°, 7°, 15°, 30°
 Angular Resolution: 1.6°
 Update Rate: up to 40 Hz

eIQ Imaging Mode

Horizontal Field of View: 140°
 Vertical Beamwidth: 30°
 Angular Resolution: 0.95°
 Update Rate: up to 10 Hz

Profiling Mode

Horizontal Field of View: 120°
 Vertical Beamwidth: 3°
 Number of Beams: 256
 Update Rate: up to 40 Hz

Interface Specifications

Communication: Ethernet
 Data Rates: 10/100/1000 Mbps
 Input Voltage: 12 to 36 VDC
 Input Power: 22 W (typical)
 Operating System: Windows 7 Professional SP1 or Windows XP Professional SP3

Environmental Specifications

Temperature
 Operation: -2°C to +38°C
 Storage: -40°C to +55°C

Shock and Vibration

Shock Qualified: +/-50gs, 3 Axes, 6 shocks per axis
 Vibration Qualified: 4g, 30Hz 3 Axes, 2 hours per axis.
 No resonance below 800Hz

Mechanical Specifications

Dimensions: (see diagram below)
 Weight in Air: 4.6kg
 Weight in Water: 1.7kg
 Depth Rating: 500m
 Connector Type: SEA CON®
 Connector Model: MINK-10-FCRL
 Materials: Hard Anodized Aluminum, Stainless Steel 316, Elastomeric Polyurethane

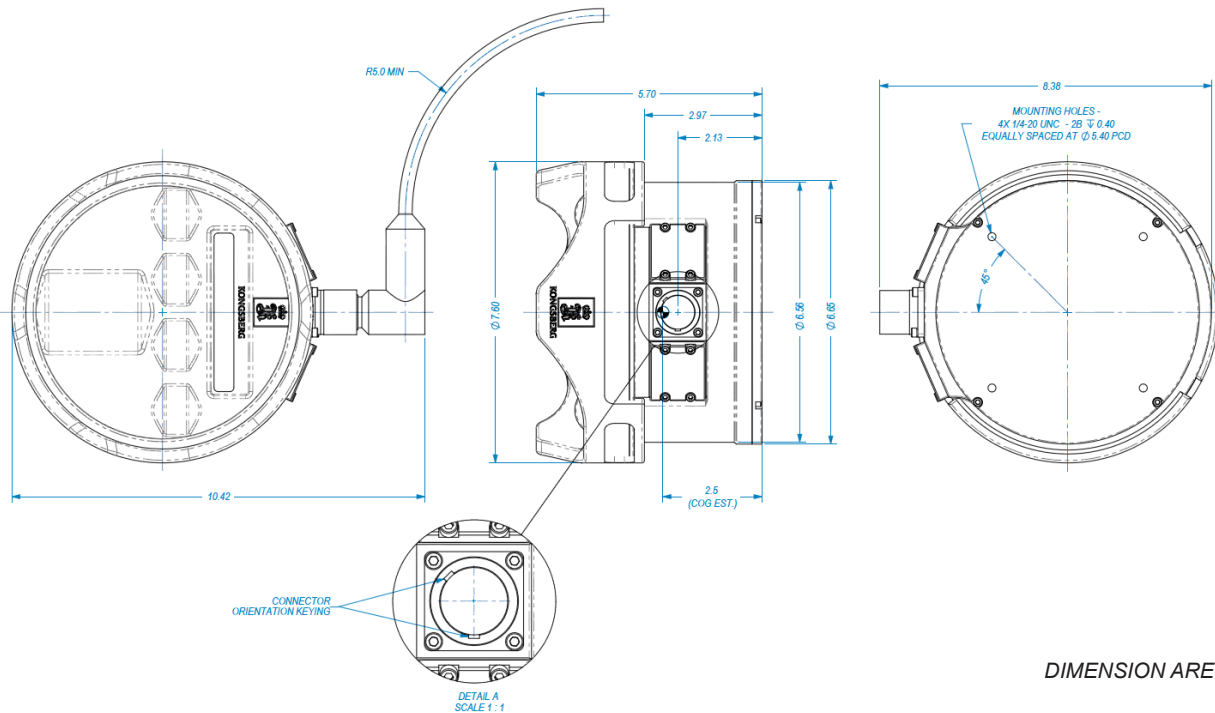

DIMENSION ARE IN INCHES

Specifications subject to change without any further notice.

922-20017901-1.3

